

Embedded Electricity Generation is becoming a more common occurrence in properties as part of an energy efficient and low carbon installation. Embedded generation can take many forms including:

- Solar Photovoltaic (PV)
- CHP (and micro CHP)
- Wind Power

Can VPhase be connected to a house containing embedded generation?

Yes, however simple rules should be observed:

Due to legislation (G83/1, BS EN 50438) the embedded generation must not supply power through a VPhase VX1 optimised circuit. I.e. do not plug embedded generation directly into a VPhase optimised socket outlet or fused spur. Always connect the embedded generation to an independent circuit at the consumer unit. Legislation requires that embedded generation must be automatically disconnected if the utility (supply) voltage rises above 264V. Therefore the embedded generation must not be connected directly to a VPhase optimised circuit. An example of a consumer unit containing embedded generation is given:

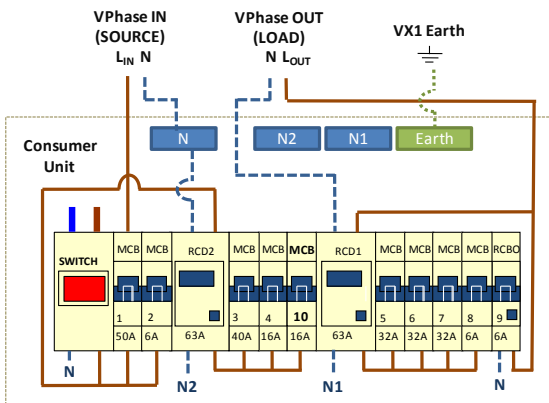

MCB	Circuit
N ^o 1: 50A	VPhase supply
N ^o 2: 6A	Fire alarm (not RCD protected)
RCD2 Protected ways (NOT supplied by VPhase)	
N ^o 3: 40A	Electric shower
N ^o 4: 16A	Electric immersion heater
N ^o 10: 16A	<i>Embedded Generation</i>
RCD1 Protected ways (Voltage Optimised: Supplied by VPhase)	
N ^o 5: 32A	Socket Ring Circuit
N ^o 6: 32A	Socket Ring Circuit
N ^o 7: 32A	Socket Ring Circuit
N ^o 8: 6A	Lighting Circuit
RCBO Protected way (Voltage Optimised: Supplied by VPhase)	
N ^o 9: 6A	Lighting Circuit (Separated from RCD1 to conform with wiring reg 314)

The embedded generation must not be directly connected to voltage optimised circuits 5 to 9. In this example an extra non-voltage optimised circuit has been included (Circuit 10) connected at RCD2 for the embedded generation.

Will the embedded generation continue to supply all of the electrical loads at the property?

Yes.

Loads on the VPhase supplied voltage optimised circuits will still be supplied with power from your embedded generation. Electric current will flow from your embedded generation through the VPhase and on to the Voltage optimised circuits. The current path will be as shown:

